

# *Slim* Line

- S.L.A. surface and torque adjustable ridge spreader enable immediate or early loading
- Mini ball (Ø 1.8) & metal socket make denture production easy
- Wide choice range of prosthetic options



# Mini Ball Type Characteristics

(Unit:mm)

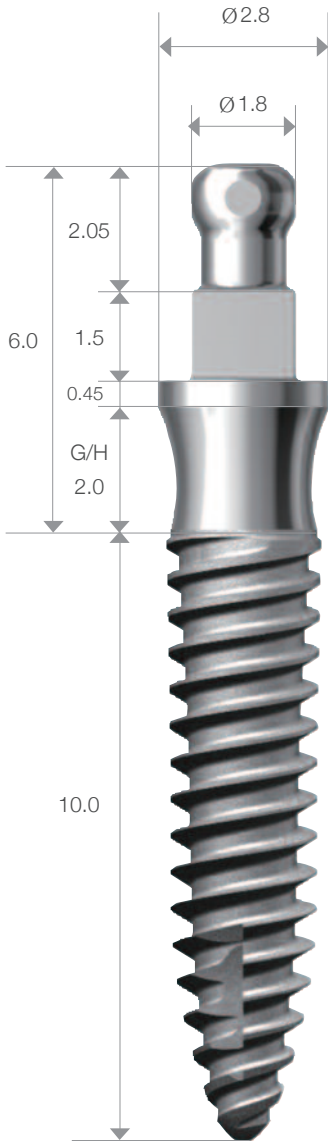

EBS252010

## Denture System



- Mini ball size (Ø 1.8)
- Mini o-ring type denture socket.
- Minimal-size denture socket.
- Mini o-ring can be replaced.

## Mini O-Ring Retention Force

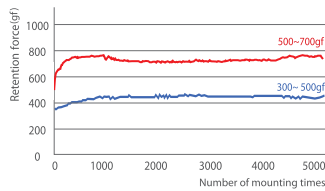

## Tilting Angle



Up to ±15 degrees of angle tilted for path way of implant.

## Angled Abutment

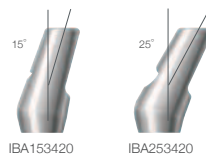

- Slanted implanting is possible with combination of angled abutment (15°, 25°).
- Cement the final restoration onto the abutment.

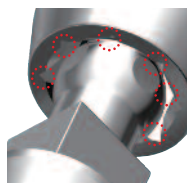

Selecting direction is easy thanks to the Octa 45° rotation angles.

# Fix Type Characteristics

(Unit:mm)

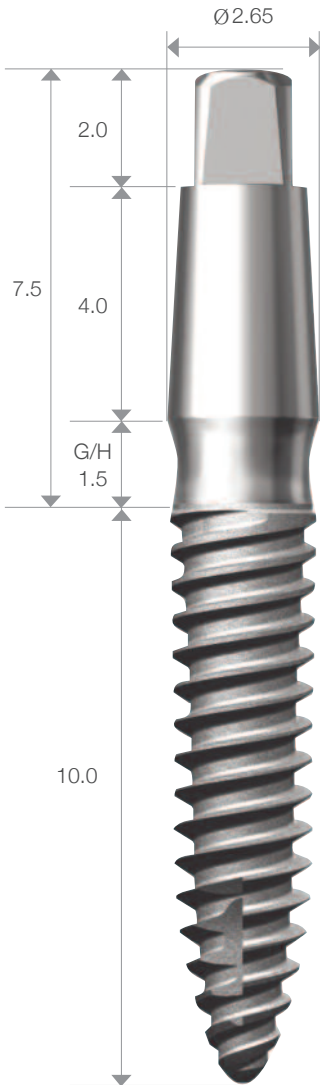

## Double Thread Design

- Increased thread height helps strengthen the initial stability.
- Double thread helps decrease the chair time of implantation.

## S.L.A. Surface

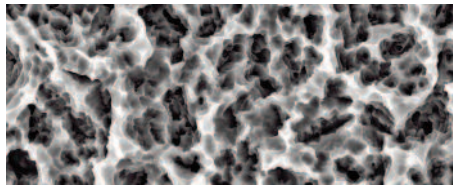

## In vivo test

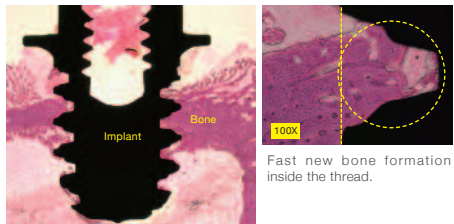

## Human osteoblast

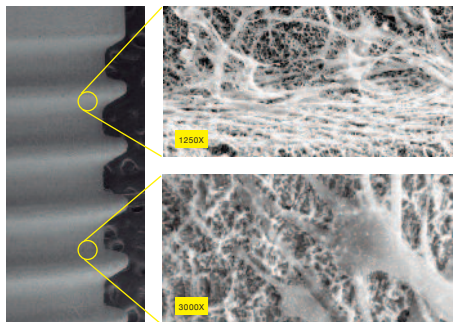

Cell number  $3 \times 10^4$ , After 7 days of cell culture

EUS251510

# SlimLine Fixture

Unit:mm, Scale 1:1.5 / mm

## Mini Ball Type Fixture

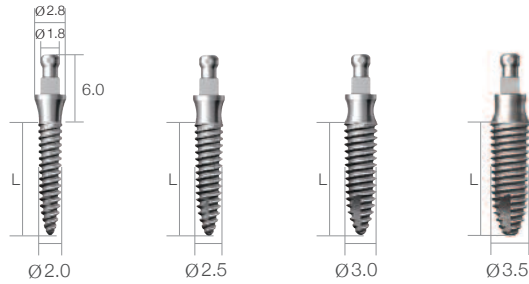

L	Body $\varnothing 2.0$	Body $\varnothing 2.5$	Body $\varnothing 3.0$	Body $\varnothing 3.5$
06	EBS 2020 <b>06</b>	EBS 2520 <b>06</b>	EBS 3020 <b>06</b>	EBS 3520 <b>06</b>
08	EBS 2020 <b>08</b>	EBS 2520 <b>08</b>	EBS 3020 <b>08</b>	EBS 3520 <b>08</b>
10	EBS 2020 <b>10</b>	EBS 2520 <b>10</b>	EBS 3020 <b>10</b>	EBS 3520 <b>10</b>
12	EBS 2020 <b>12</b>	EBS 2520 <b>12</b>	EBS 3020 <b>12</b>	EBS 3520 <b>12</b>
14	EBS 2020 <b>14</b>	EBS 2520 <b>14</b>	EBS 3020 <b>14</b>	EBS 3520 <b>14</b>

## Fix Type Fixture

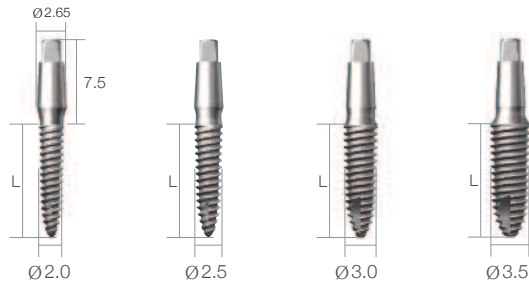

L	Body $\varnothing 2.0$	Body $\varnothing 2.5$	Body $\varnothing 3.0$	Body $\varnothing 3.5$
06	EUS 2015 <b>06</b>	EUS 2515 <b>06</b>	EUS 3015 <b>06</b>	EUS 3515 <b>06</b>
08	EUS 2015 <b>08</b>	EUS 2515 <b>08</b>	EUS 3015 <b>08</b>	EUS 3515 <b>08</b>
10	EUS 2015 <b>10</b>	EUS 2515 <b>10</b>	EUS 3015 <b>10</b>	EUS 3515 <b>10</b>
12	EUS 2015 <b>12</b>	EUS 2515 <b>12</b>	EUS 3015 <b>12</b>	EUS 3515 <b>12</b>
14	EUS 2015 <b>14</b>	EUS 2515 <b>14</b>	EUS 3015 <b>14</b>	EUS 3515 <b>14</b>

# SlimLine Products

Unit:mm, Scale 1:1.5 / mm

## Denture Components

### Comfort Cap

Art. No.	ICC
----------	-----



### Impression Coping

Art. No.	ICA
----------	-----

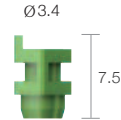

### Analog

Art. No.	IANF15T
----------	---------

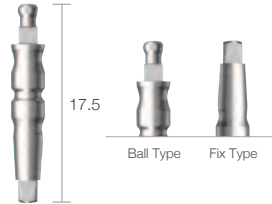

### Socket Spacer

Art. No.	BIC3L
----------	-------



### Female Socket

Art. No.	BPF3 (300~500gf)
	BPF2 (500~700gf)

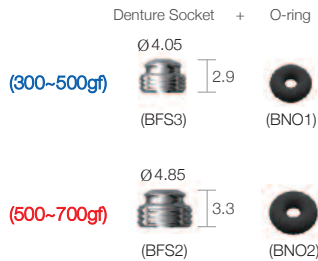

# SlimLine Products

Unit:mm, Scale 1:1.5 / mm

## Mini Ball Type Abutment

### Angled Abutment

Angled	Art. No.
15°	IBA153420
25°	IBA253420

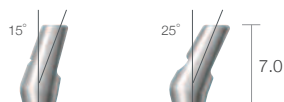

## Fix Type Abutment

### Dual Abutment

Diameter	Art. No.
Ø3.5	IUDA3510
	IUDA3520
	IUDA3530
Ø4.5	IUDA4510
	IUDA4520
	IUDA4530

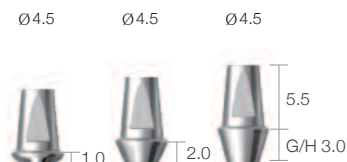
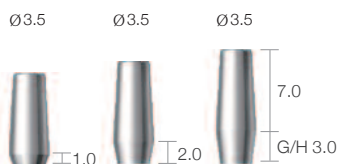

### Angled Abutment

Angled	Art. No.
15°	IUA153720
25°	IUA253720



# SlimLine Products

Unit:mm, Scale 1:1 / mm

## Fix Type Dual Abutment

- Abutment Level Impression Components

### Comfort Cap

Art. No.	CCC45C



### Impression Coping

Art. No.	CIC45L

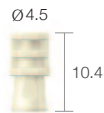

### Lab Analog

Art. No.	CAN45LL

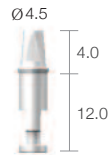

### Burn-out Cylinder

Type	Art. No.
Single	CBC45SL
Bridge	CBC45BL





# Surgical Kit



Art. No.	XIFS
----------	------

## Kit Contents

	Pilot Drill		Implant Driver H/P
XFD1135		IPST25H	
	Guide Drill I		Implant Driver T/W
XFD1635		IPST25W	
	Guide Drill II		Driver (Manual)
XFD2135		XHDHT	
	Final Drill		Parallel Pin x 4
XFD3435		XPP131822	
	Ridge Spreader		Ratchet Adapter
RS201036R		XRA3917	
RS251036R			Drill Extension
RS301036R		XDE	
RS351036R			
RS381036R			
	Ratchet		
XRCA1			

## Pilot Drill

Diameter	Art. No.
Ø1.1	XFD1135



Unit:mm, Scale 1:1 / mm

## Guide Drill

Diameter	Art. No.
Ø1.6	XFD1635
Ø2.1	XFD2135

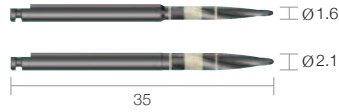

## Final Drill

Diameter	Art. No.
Ø2.85	XFD3435

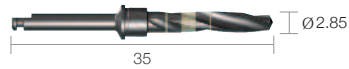

## Ridge Spreader

Diameter	Art. No.
Ø1.95	RS201036R
Ø2.35	RS251036R
Ø2.70	RS301036R
Ø3.40	RS351036R
Ø3.80	RS381036R

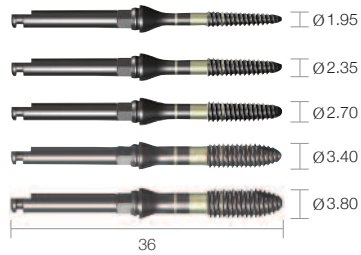

## Implant Driver

Type	Art. No.
Hand-piece	IPST25H
Ratchet	IPST25W

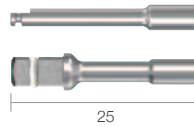

## Driver

Type	Art. No.
Manual	XHDHT



## Parallel Pin

Art. No.	XPP131822
----------	-----------

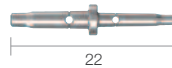

## Ratchet Adapter

Art. No.	XRA3917
----------	---------

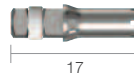

## Drill Extension

Art. No.	XDE
----------	-----

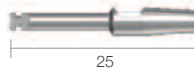

## Ratchet | Scale 1:0.5 / mm

Art. No.	XRCA1
----------	-------



# Drilling Sequence Guide

- Pilot & Guide Drill: 1,000rpm / 30~45N·cm
- Ridge Spreader: 20rpm / 30~45N·cm

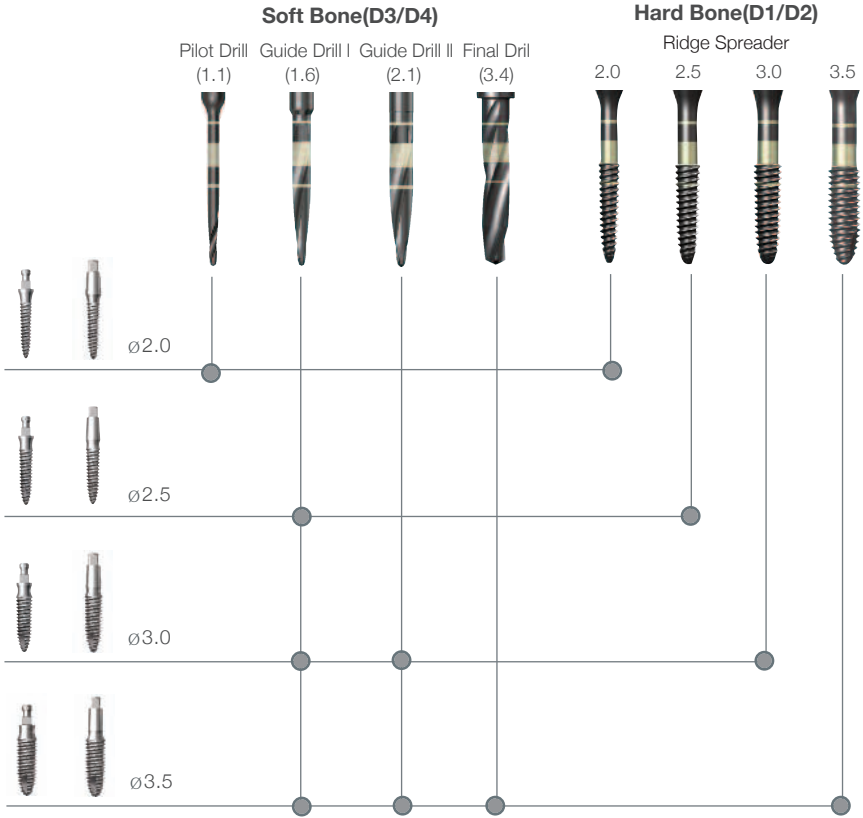

## Ridge Spreader Hard Bone (D1/D2)

Ridge spreader not only widens the drill hole, but also has the self tapping function to create internal threads in the hole.



In case of hard bone, use the ridge spreader in advance to avoid excessive torque for implantation. For direct usage of the ratchet, put the adapter on.

# Surgical Process

## Implantation Process:



Use the cap to start implantation of the fixture first. When the linkage between the cap and fixture deforms after reaching 5N.cm of tightening force, remove the disengaged cap and continue implantation using the MF tool in the surgical kit.

Please make are sure that the Fixture and Implant Driver are engaged completely before loading.

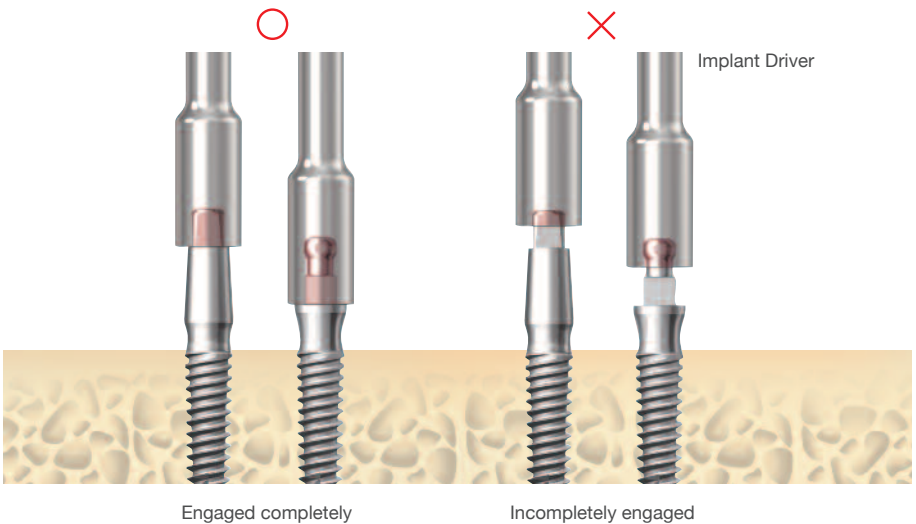

# Prosthetic Process

Fix Type Angled Abutment Cementation:

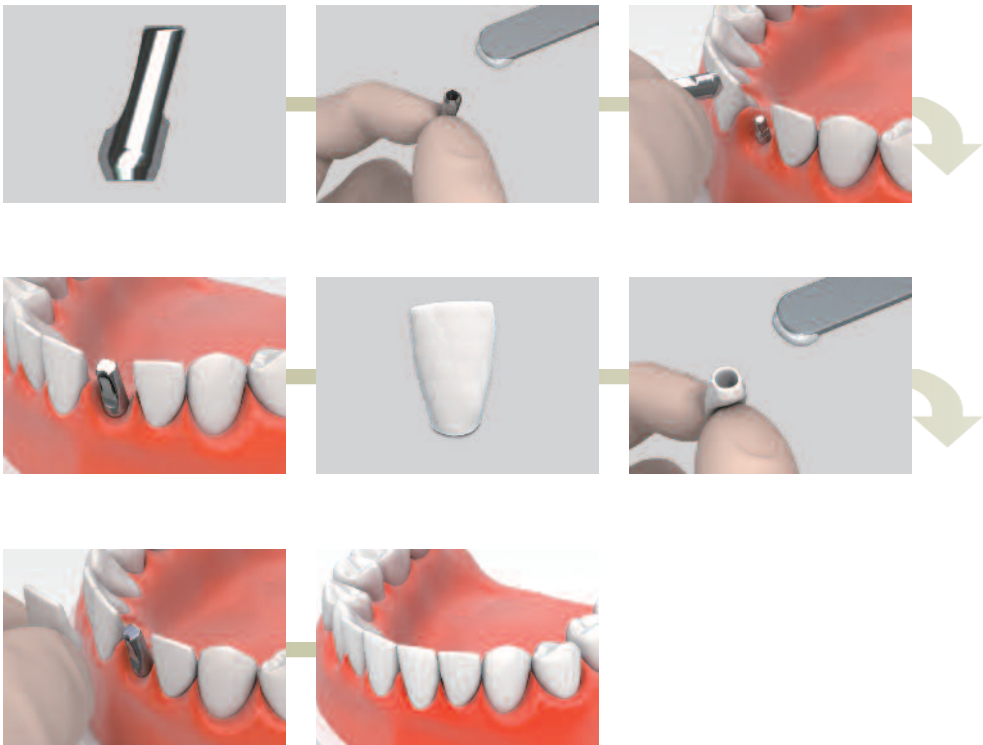

# Prosthetic Manual

## Chairside



SlimLine mini ball type fixture

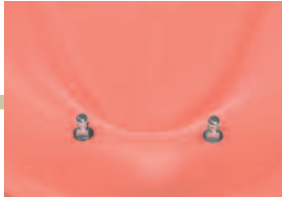

Fixture installation



Making the individual tray for denture impression

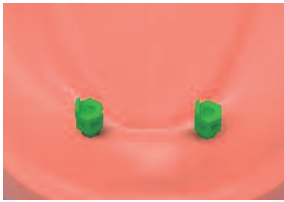

Snap on the impression coping with mini ball type fixture.

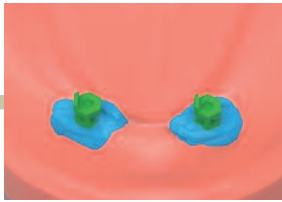

Inject the impression material.

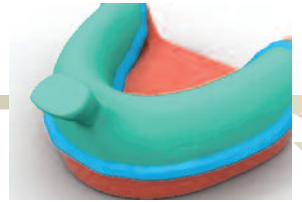

Impression taking with individual tray



Remove the tray from the oral cavity.

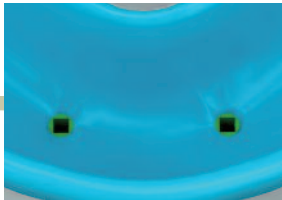

Inner side of impression



Ball analog

## Lab Side



Insert analogs into the coping embedded in impression, and stone pouring.



Master model

# Prosthetic Manual-Indirect

## Indirect

### Lab Side

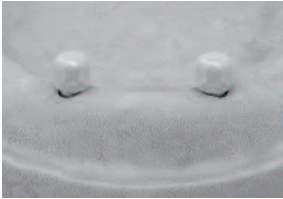

Socket spacer



Fabrication of denture with conventional method



Space for the female socket is secured.



Female sockets on the ball abutments are assembled of master model.



Apply the resin to the secured area.



Position the denture to the master model and wait for setting.

### Chairside



Female socket are placed in the denture



Polish the denture.



Denture delivery

# Prosthetic Manual-Direct

## Direct

### Lab Side



Socket spacer



Fabrication of denture with conventional method



Space for the female socket is secured.

### Chairside



Assemble the female sockets with ball abutments in the intra-oral.

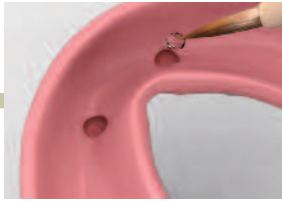

Apply the resin to the secured area.



Position the denture into the mouth and wait for setting.



Female sockets are placed in the denture



Polish the denture.

# *Slim* Lr̄ne

**Dentium**  
For Dentists By Dentists

Specifications are subject to change without prior notice.  
Some products to be launched in the market after necessary approvals are also listed in this catalog.  
Not all products listed in this catalog are available in all countries.

**HEAD OFFICE**

3105 Trade Tower 159, Samsung-dong, Gangnam-gu, Seoul, Korea 135-729 T+82-2-501-8560 F+82-2-567-9578

**HOMEPAGE**

[www.dentium.com](http://www.dentium.com)

SOB-1107 [Rev.2]